

Power Strap Feeder

Semi automatic, operator controlled pack and pallet strapping station

Improved line productivity

Faster strapping, can be completed by one operator who can focus on other important tasks.

Simpler workplace

Easier to strap loads with reduced work effort also removing the need to cross conveyors.

Low investment high return

A step-up from simple manual work with basic foot-pedal controls and easy-use battery tools.

Lowest service needs

Straightforward with few wear-parts, very simple air-motor drive for lowest cost of ownership.

PSF

Power Strap Feeder



PSF Customer Benefits

- Robust and proven design with minimal wearing parts.
- Chute flaps from stainless steel so minimal or low / no wear, service needs only on air supply, regular checks as normal.
- Designed and built with readily available, highly durable and off-the-shelf industrial components.
- Foot pedal controls to open feed unit and feed strap in to the chute system around the packager.
- More effective load strapping than by hand as strap feed speed around the load is high.
- No manual strap feeding around load, easy to remove strap and apply with battery tools.
- Easier work for operators can apply strap to a load without walking across conveyors.
- Reduced potential for injury, less bending needed in packaging process.
- Strapping tool suspended on integrated jibcrane, for effortless use.
- Easy and simple integration in to existing or new roller conveyor / chain conveyor packaging lines.
- Other load size options available in 500 mm wider / higher pack options.
- Other strap dimension options (13 mm) and strap types (PP) on request.
- Optional systems include bayonets for through the void pallet strapping, indexing model for long packs, integrated turntable for pallet load cross-strapping.
- Simple low-cost investment for low to medium throughput lines where full automation, cannot be justified.
- All electric options for bayonet, indexing and turntable models for simple connection and utilisation.

PSF Technical Specifications

Strap type	Tenax / Tenax-E Polyester
Strap feed speed	3,1 m/sec
Strap width	16 - 19 mm
Strap thickness	0,8 mm - 1,3 mm
Electric connection	230V, 1 Ph, 50Hz
Air connection	Ø 8 mm, 6 Bar
Air consumption	25 L/cycle
Noise level	85 DBA

Package Dimensions (Standard)

Min. package height	500 mm
Max. package height	1,200 mm
Min. package width	600 mm
Max. package width	1,200 mm
Package length	Unlimited
Weight without strap dispenser	110 kg
Colour	Framework: Black RAL 9005

Dimensions:

Illustrations show PSF machine.
All dimensions in mm.

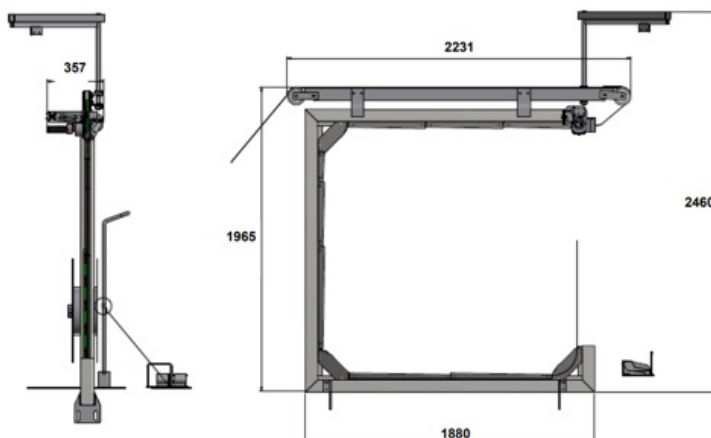

Equipment Options

Bayonet for pallets	Electrically powered bayonet drive motor
Indexing unit along load	Electrically powered Indexing drive motor
Alternative strap dispenser model	To suit strap type and customer plant lay-out
Turntable under PSF	For pallet load cross-strapping